

TONE® POWER DIGITORQON

INSTRUCTION MANUAL

No. 1601

**TO BE
PRESERVED**

MODEL

PDX-301N / PDX-302N (N.m)
PDX-501N / PDX-502N (N.m)
PDX-301F / PDX 501F (lbf.ft)

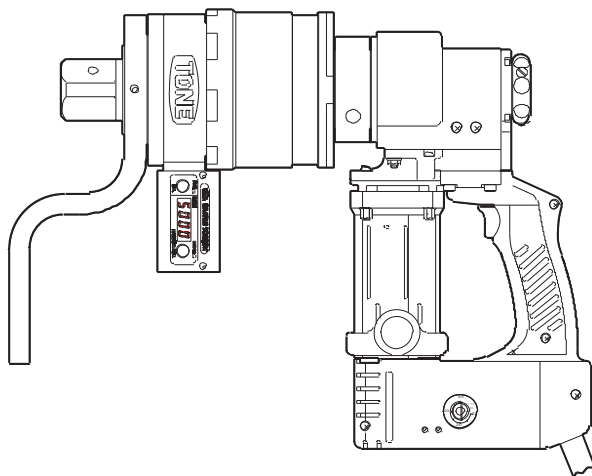

⚠ CAUTION

- Read and fully understand all the instructions before use.
- Keep this manual in designated place for easy and quick reference.
- The model mentioned on this manual is designed for use outside of Japan.
Warranty shall be void if above mentioned model is used in Japan.

TONE CO., LTD.

INTRODUCTION

Thank you for purchasing **STONE** **POWER DIGITORQON**

- Upon receipt, check and confirm the following:
 - Check any transport damages.
 - Check for any loose or lost screws and bolts.
 - Check the model as per order.
 - Check all the accessories are contained. (see page 16)

If any problems are found, contact your distributor.

- Read this instruction manual carefully before use.
Full understanding of manual is essential to prevent bodily injury or malfunction.
- Keep this manual in a bag attached to the back of metal case lid for easy and quick reference.
- If manual or warning label is lost or becomes illegible, or if additional manual is required, contact your distributor.

If you have any questions about the products or the contents of this instruction manual, contact your distributor.



- This manual is only applicable to outside of Japan, it may not use in Japan.

SAFETY INSTRUCTIONS

This manual specifies three (3) basic safety instructions:



■ Instructions are classified by degree of risk and described as follows:

	Danger is used to indicate threatening dangerous or unsafe practices which could imminently result in severe personal injury or death in the worst case.
	Warning is used to indicate hazardous or unsafe practices which could result in severe personal injury or death in the worst occasion.
	Caution is used to indicate hazardous or unsafe practices which could result in personal injury or product or property damage.

Even if the risk is classified as  , risk could become more serious result depending on conditions. Make sure to follow all instructions when in operation.

TABLE OF CONTENTS

1. Application	4
2.  Precautions for Use	4
3. Part Name & Accessories	15
4. Before Use	18
5. Changing Accessories	20
6. Operating Procedure	29
7. Setting Preset Torque	35
8. Using Display	37
9. microSD Memory Card Storage Format	53
10. Changing Batteries	56
11. Error and Status Indication	
12. Maintenance	61
13. Periodic Inspection	62
14. Features	63
15. Specifications	64
16. After-Sales Service	65

1. Application

- **POWER DIGITORQON** is an electric torque control wrench with digital torque indicator that shows actual tightening torque being applied on bolts/nuts.

2. Precaution for Use

- To prevent fire, electric shock, bodily injury and etc, read and follow all instructions listed below.

DANGER

- **Beware of electric shock at high working place.**

Electric shock at high working place may result in dangerous tumble down.



About Double Insulation

This electric wrench has double insulation structure. Double insulation is designed to improve electrical safety by having two layers of insulating materials surrounding live parts. All wrenches with double insulation structure are IEC protection class “Class II” appliance and are labeled by double insulation symbol of .

Using the non-conformed replacement parts or improper assembly work will make the double insulation ineffective, causing personal injury or accident. Contact your distributor when assembly, replacement, repair or etc is needed.

⚠ DANGER

● **Do not put hands, fingers or feet close to the reaction plate during operation.**

- The reaction plate rotates in the direction opposite to that of bolt and nut rotation.
- Never place hands, fingers or feet where reaction plate is placed.

Failure to follow this instruction may result in amputation of hands, fingers or feet.

⚠ DANGER

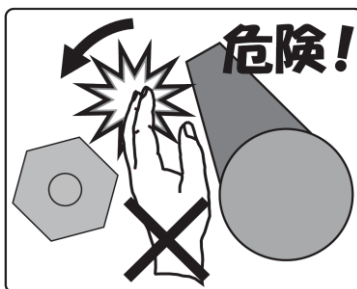

⚠ WARNING

● **Firmly hold the wrench with both hands during operation.**

- The wrench automatically shuts off when tightening is completed. Prepare for automatic shut off by firmly holding the wrench with both hands as reaction force maximizes just before automatic shut off.

Failure to follow this instruction may result in personal injury.

● **Beware of electric shock.**

- Do not use wrench in rain, snow, wet or humid condition.
- Never touch the power plug with wet hands.

Failure to follow this instruction may result in electric shock, fire or electrical leakage.

● **Check electric cord periodically.**

- If it is damaged, contact your distributor for repair service.

⚠ WARNING

● **Never use the wrench in a location where flammable substances such as gasoline, gas, thinner, benzene and etc. are stored.**

- The trigger switch emits sparks when it is turned on/off.
The commutator motor also emits sparks when it is rotating.
Failure to follow this instruction may result in explosion or fire.

● **Avoid accidental starting.**

- Do not carry the wrench with your finger on the trigger switch when it is connected to the power source.

Accidental start may result in personal injury.

● **Disconnect the plug from the power source when:**

- the wrench is not used.
- accessories are changed.
- inspection/maintenance is carried out.
- trouble or danger is foreseen.

Accidental start may result in personal injury.

● **Immediately turn off the power and disconnect the plug when abnormal sound, vibration or smell is detected during operation.**

- Contact your distributor for advice.

Continued use may result in electric shock, fire or personal injury.

● **Operate the wrench at the voltage specified on the rating plate.**

Failure to follow this instruction may result in fire, burn or personal injury.

● **Place reaction plate parallel to the torque indicating display.**

- Refer to the figure shown right.

Incorrect installation may damage the torque indicating display, moreover, may result in personal injury.

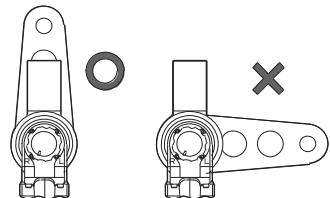



WARNING

● Place the reaction plate to a solid member.

- Select solid member or surface to be placed the reaction plate as those member or surface receives load almost equivalent to that of output torque.

Failure to follow this instruction may result in loss of torque precision; damage or deformation of reaction plate or its set screws; or damage or seizure of the wrench.

● Place the reaction plate to a stable section.

- If stable section is not available, set protective buffer plate (e.g. steel splice plate) in place where reaction plate is going to be placed.

Protective buffer plate must be securely placed.

Loose buffer plate may invite accident and personal injury.

● Correctly install pin and O-ring on the socket.

- Incorrectly mounted socket may drop off when carrying the wrench or during operation.

Loose socket may invite personal injury.

● Beware of fall down accident when working at a high place.

- Wear safely belt.
- Provide safety net or canvas as safeguard against falling items.
- Confirm that no one is underneath the working site before operation.
- Stop operation when physically or mentally tired.

Failure to follow these instructions may result in fall down accident.

● Immediately check the wrench when it is dropped down or banged.

- Check for deformation, crack, damage and other abnormality. Stop using the wrench if any abnormality is found.

Continued use of faulty wrench may result in electric shock, fire burn or personal injury.



WARNING

- **Avoid overloading.**

- Use the wrench and its accessories within the rated specification.

Overloading of the wrench and its accessories may result in damage of the wrench or its accessories; or accident or personal injury.

- **Properly install the socket and reaction plate as described in this manual.**

Incomplete installation may result in accident and personal injury.

See “Changing Accessories” on page 18.

- **Do not disassemble or modify the wrench.**

Disassembly or modification made by unauthorized personnel may result in electric shock, fire, malfunction, injury or loss of torque precision.

Disassembly/reassembly is permitted for following expendables:

Carbon Brush, Reaction Plate, Socket, O-ring, Pin and Battery.

- **When not in use, store the wrench in the metal case and keep it in the designated place.**

- Store the wrench in lockable dry location to keep any unauthorized personnel away.

Failure to follow this instruction may cause malfunction or accident.

- **Contact your distributor for repair service.**

Repair work should only be done by a qualified serviceman. Repair work done by an inexperienced person may cause accident, injury or malfunction.



WARNING

● Check the following items before operation.

- Check for any deformation, crack or damage on wrench body, reaction plates, electric cord, power plug, socket, O-ring, pin, batteries, metal case, hex key wrench and screwdrivers (-).

Do not use wrench if any of the above items are abnormal.

- Make sure that the socket and the reaction plate are correctly installed on the wrench.
- Make sure that set screws for the reaction plate are securely fastened.

Loose installation may result in electric shock, fire, burn and personal injury.

● Use AA alkaline dry cells or rechargeable nickel hydride batteries only.

Failure to follow this instruction may result in fire, burn, injury, accident, malfunction, loss of torque precision or etc.

● Handle batteries with care.

- Make sure the polarity of the batteries is correct.
- Do not heat, short circuit, disassemble or throw them into the fire.
- Do not mix new and old batteries.
- Do not use AA alkaline dry cells with other types of batteries.
- Do not recharge conventional dry cell batteries.
- Immediately wash with clean water and receive medical treatment if battery electrolyte enters into eyes.
- Immediately wash with clean water if battery electrolyte adheres to skin or cloth.
- Remove the batteries when they are ran out or the wrench is going to be left unused.
- Follow other precautions written on the batteries.

Failure to follow these instructions may result in fire, burn injury, accident, malfunction, electrolyte leakage or loss of torque precision.

 **CAUTION**

● **Use commercial power supply to operate the wrench.**

● **Follow the instructions below when using generator.**

- Use 50–60Hz sinusoidal power supply without high harmonic wave.

Power supply includes high harmonic wave may cause malfunction or breakage of the wrench.

- Use high capacity generator.

Power requires almost 2kW (2kVA) per one wrench.

- The operating voltage must remain within +/- 10% of the rated voltage at all times.

- Do not use inverter generator.

Inverter generator: The engine rpm will speed up and slow down automatically due to the wattage being pulled from the generator.

Failure to follow these instructions may cause malfunction or breakage of the wrench.

● **Do not use a supplemental power of the engine welding machine.**

Some engine welding machines may generate electrical noise and damage torque control device that is incorporated in the wrench.

● **Do not use welding machine near the wrench.**

The electromagnetic interference from welding machine can affect wrench's torque control device even if welding machine is operating from the power of different generator.

● **Do not abuse electric cord.**

- Never use the electric cord for carrying, pulling, or unplugging the power.
- Keep electric cord away from heat, oil or sharp edges.

 **CAUTION**

● **Keep good motor ventilation.**

- Do not put any foreign materials in the vent.
- Do not cover the vent.

● **Do not connect multiple plugs to a single outlet by using multiple outlet adaptors.**

Over current may cause fire, accident or malfunction.

● **Provide leakage breaker as a shock guard for each wrench.**

- Use of leakage breaker is not mandatory for double insulated wrenches, however, it is recommended for safety reason.

● **When using an extension cord, make sure that voltage remains within +/- 10% of the rated voltage at all time.**

● **Extension cord must be selected from a list below.**

As the distance from the supply outlet increases, a larger gauge extension cord must be used. Using extension cord with inadequate size causes a serious drop in voltage, resulting in loss of power and overheating.

Nominal Conducting Cable Cross Section		Max. Length	
		115V	230V
H07RN-F	1.5mm ²	10m	20m
	2.5mm ²	20m	40m
	4.0mm ²	30m	60m
AWG 14		50ft	100ft
AWG 12		80ft	160ft
AWG 10		130ft	260ft

● **Observe local laws and rules for concerning noise level.**

⚠ CAUTION

- **Reaction force must be taken by area beyond “a” dimension when L-type reaction plate is used. See table below.**

There is a chance to invite overload when reaction force is taken within “a” dimension which may result in breakage of the HSH set screws, seizure of the output square drive or loss of torque precision.

Model	a (mm)
PDX-301N/PDX-302N/PDX-301F	130
PDX-501N/PDX-502N/PDX-501F	135

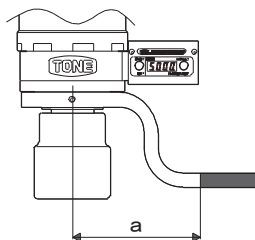

- **Fully slide the socket over the bolt/nut.**

Insufficient socket engagement may cause damage to the bolt/nut or slip off of the socket which may result in injury or malfunction of the wrench.

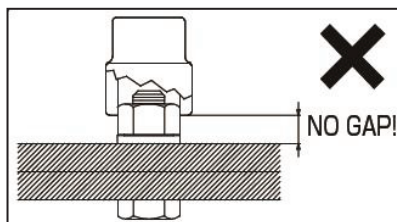

- **Do not operate wrench in extremely high or low temperature.**

Refer operating temperature in the specification.

Failure to follow this instruction may result in accident, malfunction or loss of torque precision.



CAUTION

- **Do not operate wrench in humid condition.**

- Do not operate wrench in a location subject to rain.
- Refer operating temperature in the specification.(⇨P.64)

Failure to follow this instruction may result in accident, malfunction or loss of torque precision.

- **Never use wrench under condensation occurs.**

Failure to follow this instruction may result in accident, malfunction or loss of torque precision.

- **Do not operate wrench beyond its rated torque range.**

- Refer torque range in the specifications (p. 60).

Failure to follow this instruction may result in accident, malfunction or loss of torque precision.

- **Do not operate wrench in dusty condition.**

- Prevent dust from entering the wrench.

Dust may cause performance degradation as well as malfunction or loss of torque precision.

- **Keep work area clean.**

Cluttered areas and benches invite accident.

- **Keep children away.**

- Do not let children touch the wrench and the electric cord.
- All visitors should be kept away from work area.



CAUTION

● Secure work area.

- Keep body stance balanced and firmed.
- Never wrap the electric cord around something.
- Keep work area well lit.

● Use suitable model for each application.

- Do not use wrench beyond its rated specification.
- Do not use wrench for purpose not intended.

● Dress properly.

- Always wear gloves and non-skid footwear when operating outdoor.
- Always wear safety helmet.

● Use genuine accessories and attachments manufactured by Maeda Metal Industries, Ltd.

● Maintain wrench.

- Keep wrench handle clean, dry and free of oil or grease.

● Avoid dropping and impacting.

- Handle with care when transportation.

Failure to follow this instruction may cause performance degradation as well as malfunction or loss of torque precision.

● Do not use solvent such as thinner for cleaning the wrench.

- Solvent could erase marking or paint.
- Use dry cleaning.

3. Part Name & Accessories

Part Name

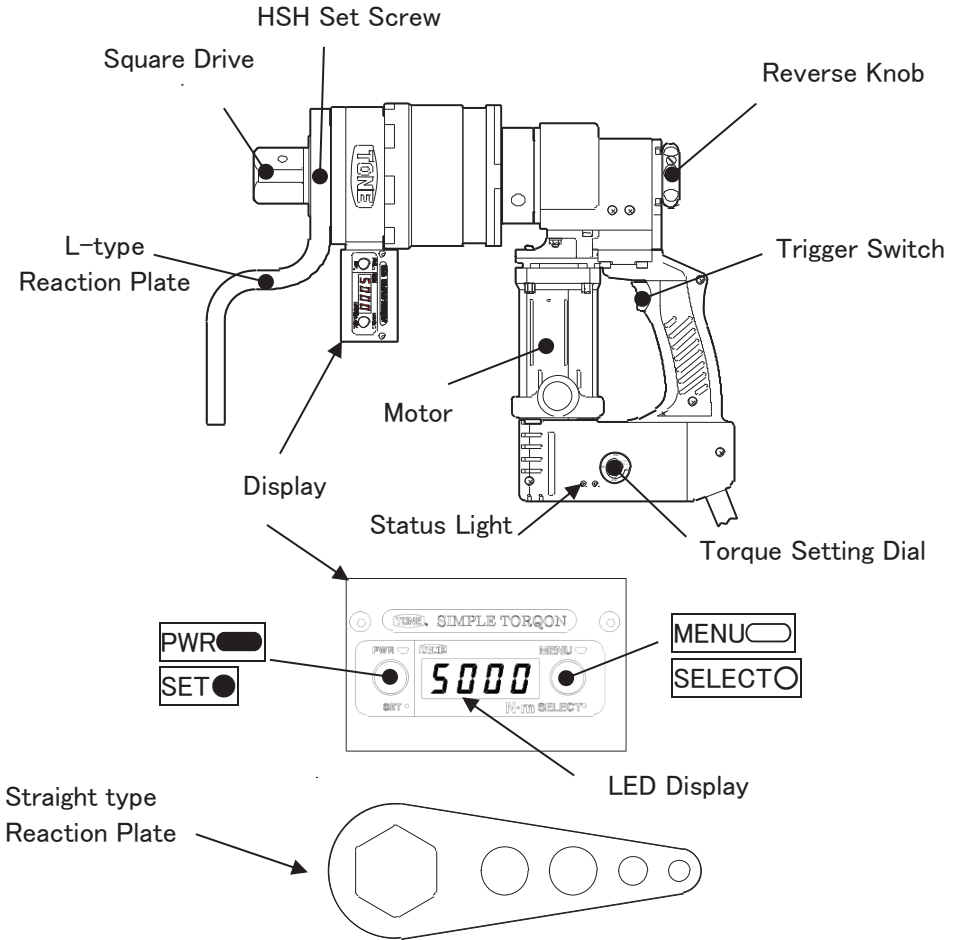

※ / Marks indicate to push more than 2 seconds

※ / Marks indicate to push less than 1 second

Accessories

Straight type Reaction Plate (factory installed)	1 pc
L-type Reaction Plate	1 pc
HSH Set Screw (2pcs factory installed, 2pcs for replacement)	4 pcs
Screwdriver (-)	1 pc
Mini Screwdriver (-)	1 pc
Hex Key Wrench *	1 pc
Metal Case	1 pc
CE Connector (only for CE models)	1 pc
Instruction Manual	1 pc
Calibration Certificate	1 pc
AA Alkaline Battery (factory installed)	4 pcs
microSD Memory Card Set	
┌ microSD Memory Card	
└ Adapter	1 set
┌ Case	
└ Instruction Manual & Warranty Certificate	

* Size of Hex Key Wrench

Model	PDX-301N / PDX-302N PDX-301F	PDX-501N / PDX-502N PDX-501F
Size	3mm	5mm

Optional Accessories

• Lifting Device	1 set
┌ Lifting Device	1 pc
└ Spacer	2 pc
┌ CRPH Screw	4 pcs

- Contact your distributor for custom made reaction plates and other optional accessories.

External Dimensions (mm)

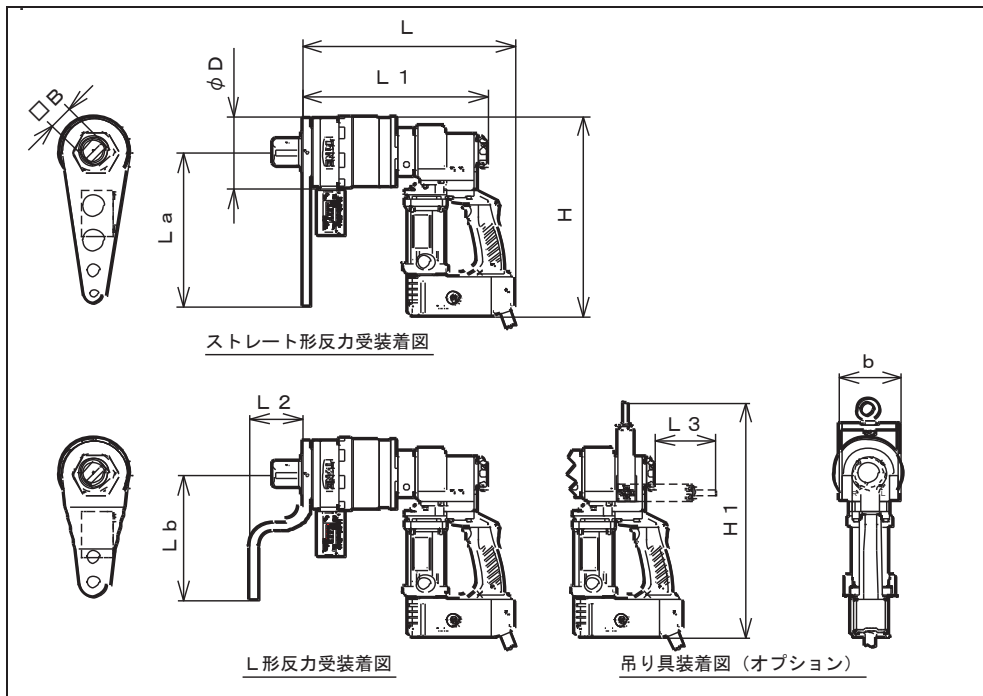

Model	b	B	D	H	H1	L	L1	L2	L3	La	Lb
PDX-301N	99	25.4	98	311	377	332	288	69	97	205	185
PDX-302N											
PDX-301F											
PDX-501N	99	38.1	117	320	377	341	297	84	97	246	200
PDX-502N											
PDX-501F											

4. Before Use

- Preparation of the wrench and procedures of torque setting are shown in the following.



WARNING

- **Check followings before connecting plug into power source.**

Failure to follow these instructions may result in serious injury due to accidental starting.

- 4.1 Check for any deformation, crack or damage on wrench body, reaction plate, electric cord, electric plug, socket, o-ring, pin and etc. before use.

Do not use wrench if any problem is found on items listed above.

Make sure that HSH set screws for reaction plate are securely fastened. Refer “Changing Accessories” on page 19.

- 4.2 Make sure to use adequate power supply and batteries.

Use adequate power source and batteries as indicated on the rating plate.

- 4.3 Make sure to use adequate socket/pin/o-ring suitable for bolt/nut to be tightened.

- 4.4 Impact socket should be securely installed on the wrench with pin and o-ring.

- 4.5 Correct insertion of microSD memory card is needed to store measured torque values in the microSD card and to review them on the computer.

4.6 Set clock (calendar year, month, date and time) of the display before use.



When tightening torque is measured without microSD memory card, the clock is used only for purpose of “5-6 Display setting state and battery power level” (See Page 19.) In this case, setting the clock is not necessary.

4.7 Activate or deactivate an “Auto Start Mode” before use.

Zero adjustment is automatically made right before each torque measurement when auto start is ON.

Manual zero adjustment is necessary each time before torque measurement when auto start is OFF. Battery last longer when auto start is OFF.

Refer “Using Display” on page 25.

4.8 About 5 minutes of warm up exercise at no-load is necessary for precise torque measurement.



CAUTION

- **The torque control wrench tend to stop right after the wrench is activated when it is set for minimum torque value and is use in temperature below 10 degrees centigrade. In such case set torque setting dial at maximum and exercise the wrench for about 5 minutes then reset the torque to target torque.**

5. Changing Accessories

5.1 Mount or Remove Reaction Plate

Mount Reaction Plate

Place reaction plate over the reaction base to make parallel installation to the display, then securely tighten by HSH set screws

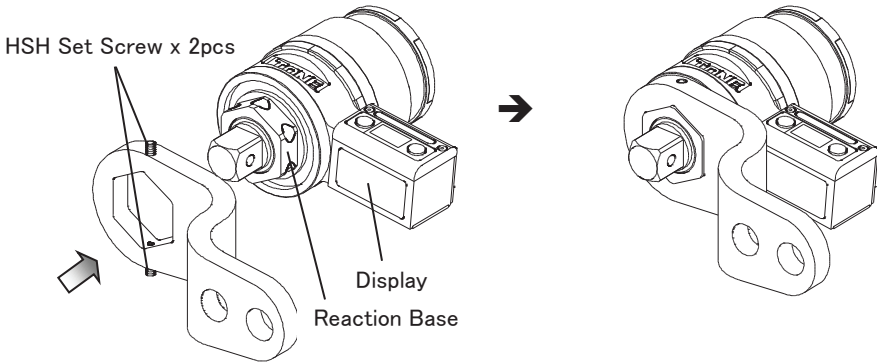

⚠ WARNING

- Reaction plate must be placed parallel to the display to prevent display from damaging.

Improper mounting cause brakeage of the display and injury.

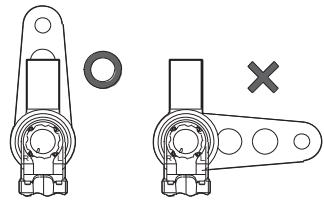

Remove Reaction Plate

Unscrew HSH set screws to remove reaction plate.

NOTE Slightly hit the reaction plate by hammer when it is adhered on the wrench body.

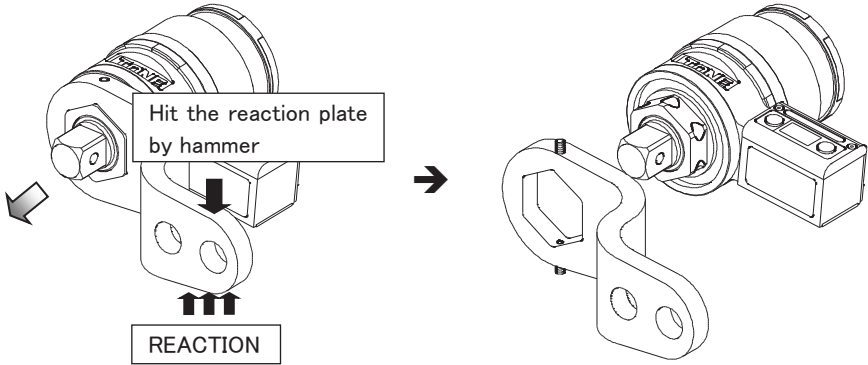

5-2. Mount or Remove Impact Socket

Mount Impact Socket

Prepare adequate impact socket/pin/o-ring suitable for bolt/nut to be tightened.

Remove pin from impact socket.

Align holes in the square drive and the impact socket.

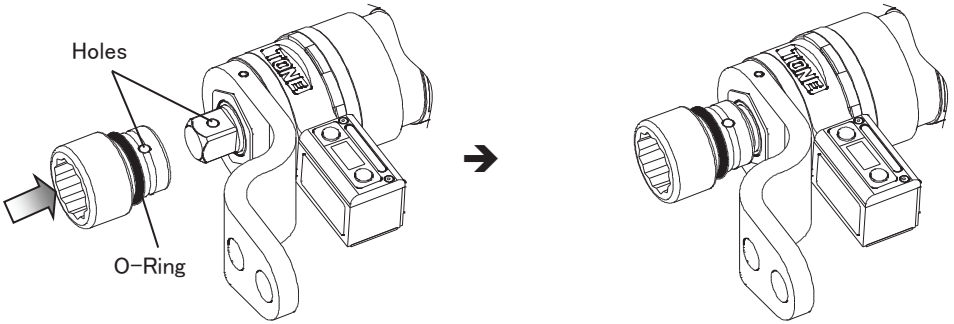

Insert pin into the aligned holes and place o-ring in the groove.

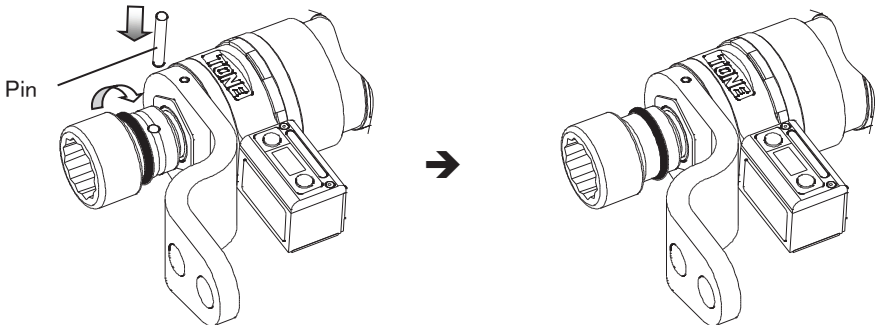

Check if impact socket is securely installed on the wrench body.

Remove Impact Socket

Remove pin from impact socket then remove impact socket from wrench body.

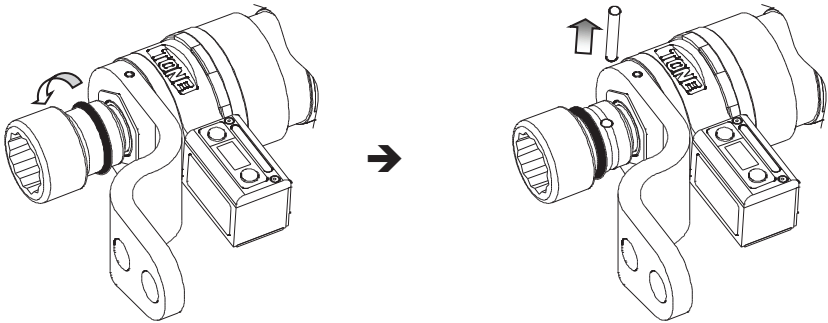

WARNING

- **Check for any deformation, crack or damage on the impact socket, pin and o-ring.**

Damaged socket, pin or o-ring invites serious injury.

Since pin and o-ring are expendables, those should be replaced with new ones from time to time.

Failure to follow these instructions may result in serious injury.

- **Make sure that impact socket is securely installed on the wrench body by pulling the socket.**

Loose fitted socket invites injury.

5-3. Insert or Remove microSD Memory Card

Make sure power is OFF.



Face battery cover up.

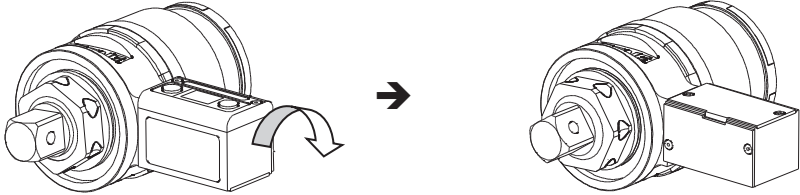

Unscrew the screws by screwdriver (+) in a set to remove battery cover.

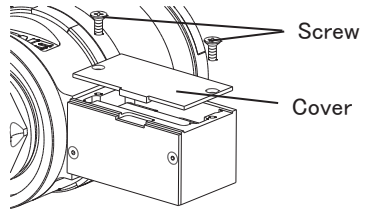

CAUTION Do not allow dust enter into the display.

CAUTION Never remove cover tightened by HSH bolts to prevent display from damage caused by static electricity.

Insert microSD Memory Card

Fully insert microSD card into the slot as shown in the figure until “click sound” is made.

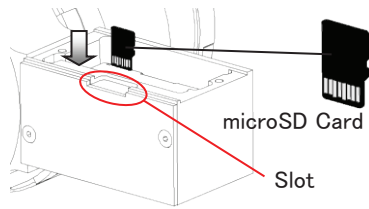

Remove microSD Memory Card

Push microSD card until “click sound” is made then remove it.

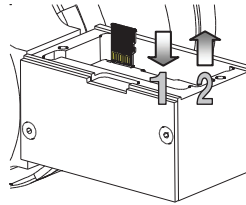

CAUTION

- **Never touch electrode, motherboard or any electronic components of the display and the microSD card.**
Static electricity could cause malfunction.
- **Up to 2GB of microSD memory card can be used on the display.**

Place cover on the display and tighten by screws.

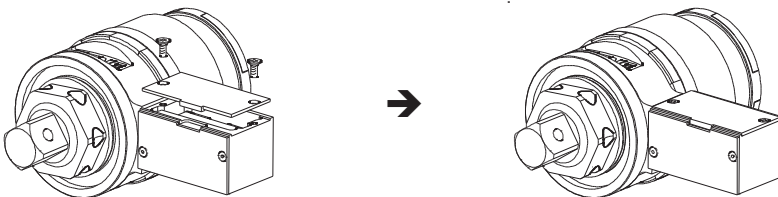

5-4. Mount or Remove Optional Lifting Device

Mount Lifting Device

Remove CRFH screws from housing.

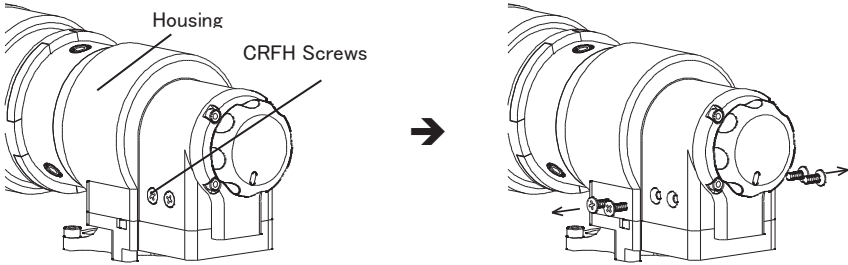

Place spacers on both side of housing and tighten them by CRPH screws.

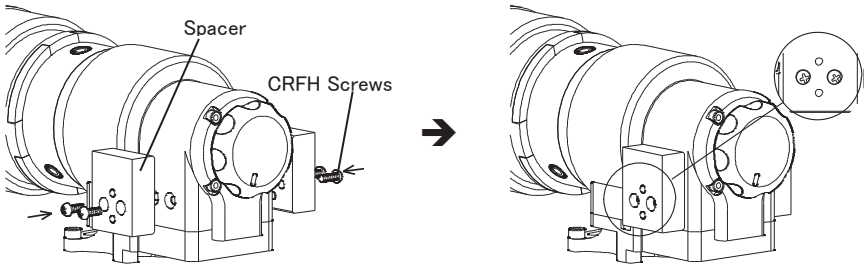

Place lifting device on the spacers at either vertical or horizontal position.

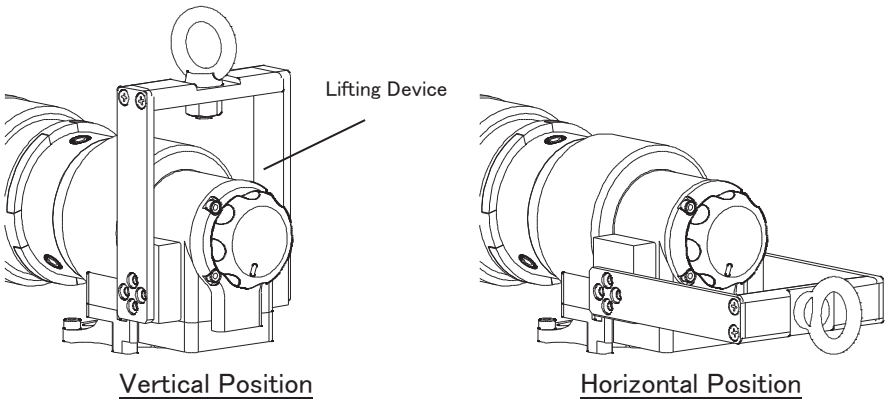

Then tighten by CRFH screws.

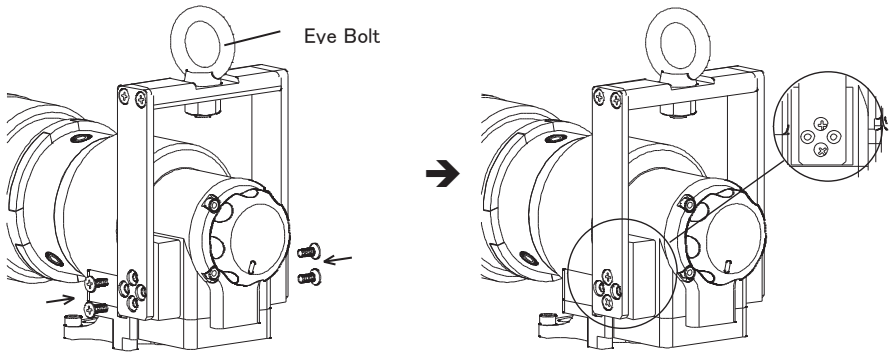

NOTE Lifting device can also be use as sub-handle by removing eye-bolt.

Make sure that lifting device is securely installed on the wrench body.

Remove Lifting Device

Remove CRFH screws from lifting device.

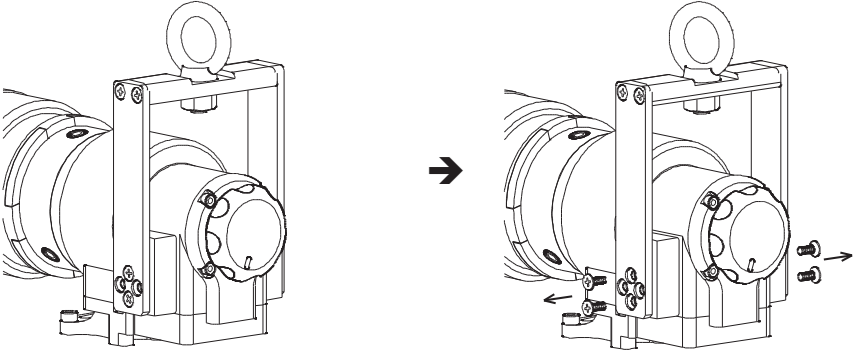

Remove CRPH screws then remove spacers.

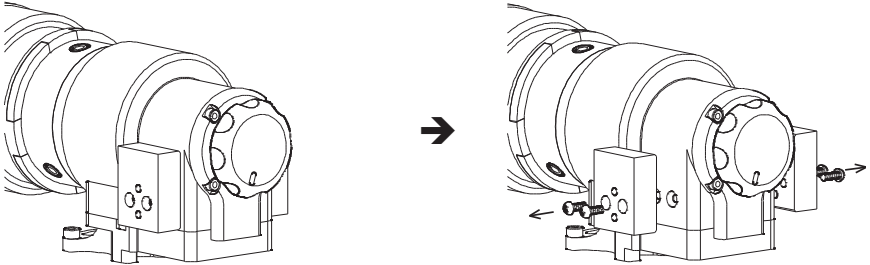

Put CRFH screws back on the housing.

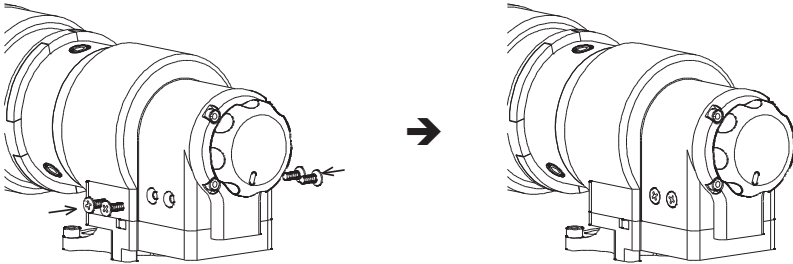

6. Operating Procedure

Run wrench at no-load for about 5 minutes.

About 5 minutes of warm up exercise at no-load is necessary for precise torque measurement.



CAUTION

- The torque control wrench tend to stop right after the wrench is activated when it is set for minimum torque value and is use in temperature below 10 degrees centigrade. In such case set torque setting dial at maximum and exercise the wrench for about 5 minutes then reset the torque to target torque.

Set reverse knob to (R) position for clockwise rotation. Activate the wrench for about 1 to 2 seconds in case reverse knob does not function well.

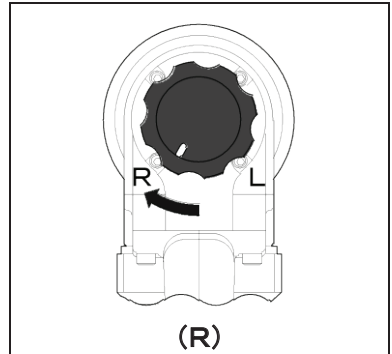

CAUTION

- Torque measurement can only be done in clockwise (R) direction.
No torque measurement in counter clockwise (L) direction.

- Direction selection (R or L) and torque setting can only be done when motor is not running.

Failure to follow these instructions may result in accident, malfunction and injury.

6-2. Turn Display ON

Push **PWR** button for more than 1 second at no-load.



Torque measurement is ready when **0** is displayed in the window.

NOTE Refer page 38



CAUTION

- Do not apply any load until window displays **0**

Precise torque measurement cannot be achieved if zero adjustment is improperly made.

6-3. Place the wrench to the bolt/nut to be tightened then properly place reaction plate on the bolt/nut adjacent to the bolt/nut to be tightened.

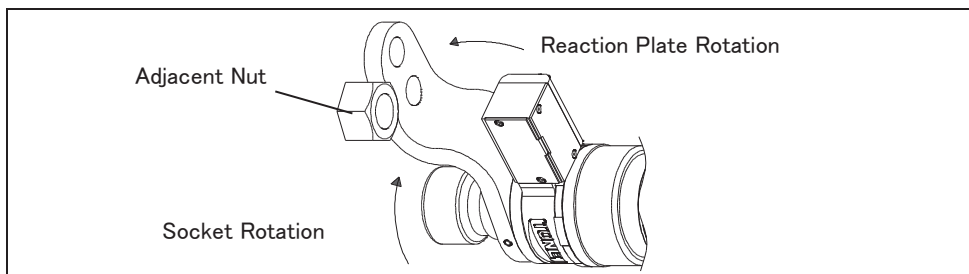

WARNING

- Do not touch reaction plate when operating.

Failure to follow this instruction may result in personal injury like finger amputation.



⚠ CAUTION

● Beware that reaction plate rotates opposite direction to that of bolt/nut rotating direction.

● Reaction force must be taken by area beyond “a” dimension when L-type reaction plate is used. See table below.

There is a chance to invite overload when reaction force is taken within “a” dimension which may result in breakage of the HSH set screws, seizure of the output square drive or loss of torque precision.

Model	a (mm)
PDX-301N/PDX-302N/PDX-301F	130
PDX-501N/PDX-502N/PDX-501F	135

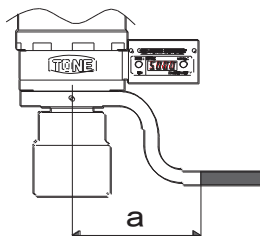

● Fully slide the socket over the bolt/nut.

Insufficient socket engagement may cause damage to the bolt/nut or slip off of the socket which may result in injury or malfunction of the wrench.

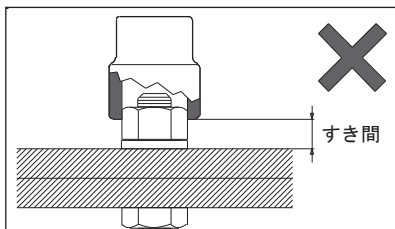

6-4. Adjust Torque Setting Dial

Adjust torque setting dial to match your target torque and measured torque on the display. Refer procedure on page 36.

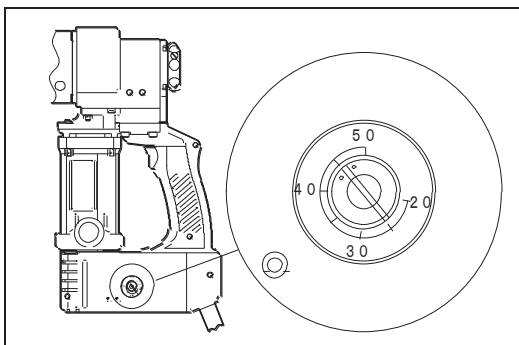

⚠ CAUTION

- Graduation on the torque setting dial is only a rough guidance.
 - Tightening torque varies depending on tightening condition.
 - It is recommended to adjust torque setting dial each day before operation or whenever tightening condition is changed.
- Gradually adjust torque setting dial from low torque to high torque to prevent over loading.

6-5. Tightening Operation

NOTE This section describes operating procedure in the auto start **OFF** mode.
Refer page 49-51 for auto start **ON**/**OFF**

NOTE Measured torque will only be stored in the microSD memory card when it is correctly inserted into the slot.

Squeeze trigger switch to activate the wrench only when window displays

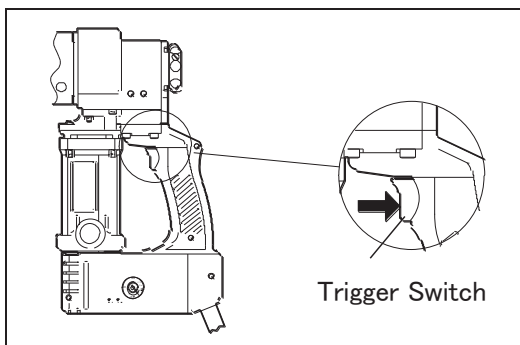

2. As tightening proceed, display reads actual tightening torque until wrench stops automatically. Peak hold torque value will appear on the display.

⚠ CAUTION

- Target torque will not be obtained if trigger switch is released before the wrench stops automatically

- ③ After tightening, there may be some cases that it is hard to take out the wrench from the bolt/nut. In those cases, set the reverse knob to (L) position for counterclockwise direction and then squeeze the trigger switch to release reaction force from the reaction member. Finally, the wrench is taken out from the bolt /nut.

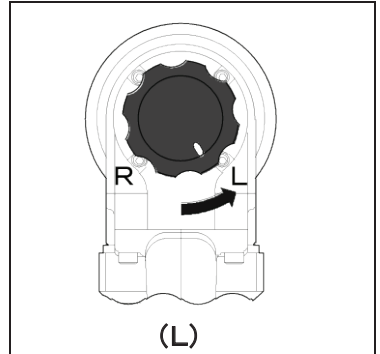

- ④ To proceed with next tightening operation, got to step 5.
To finish operation, go to step 6.
- ⑤ Push **SET** button at no-load to make zero adjustment and repeat step 1 through 3 to proceed with next tightening operation.

NOTE No manual zero adjustment is necessary when auto start is **ON**

- ⑥ When operation is finished, push **PWR** button for 3 seconds to turn display OFF (see page 41).

CAUTION

● **Confirm position of reverse knob (R or L) before operation.**

● **Avoid loosening operation with counter clockwise direction (L) other than adjusting tightening torque.**

- In case of loosening old bolts and nuts tightening once, much higher torque than the tightening torque is required.

Failure to follow this instruction may result in malfunction or accidents.

● **In order to prevent malfunction as well as over torque, never tightening the same bolts/nuts twice.**

Failure to follow this instruction may result in lack of tightening torque, breakage of bolts/nuts, malfunction and personal injury.

7. Setting Preset Torque

Graduation on the torque setting dial is only a rough guidance.

Adjust target torque by following procedure each day before operation or whenever tightening condition is changed (see page 17).

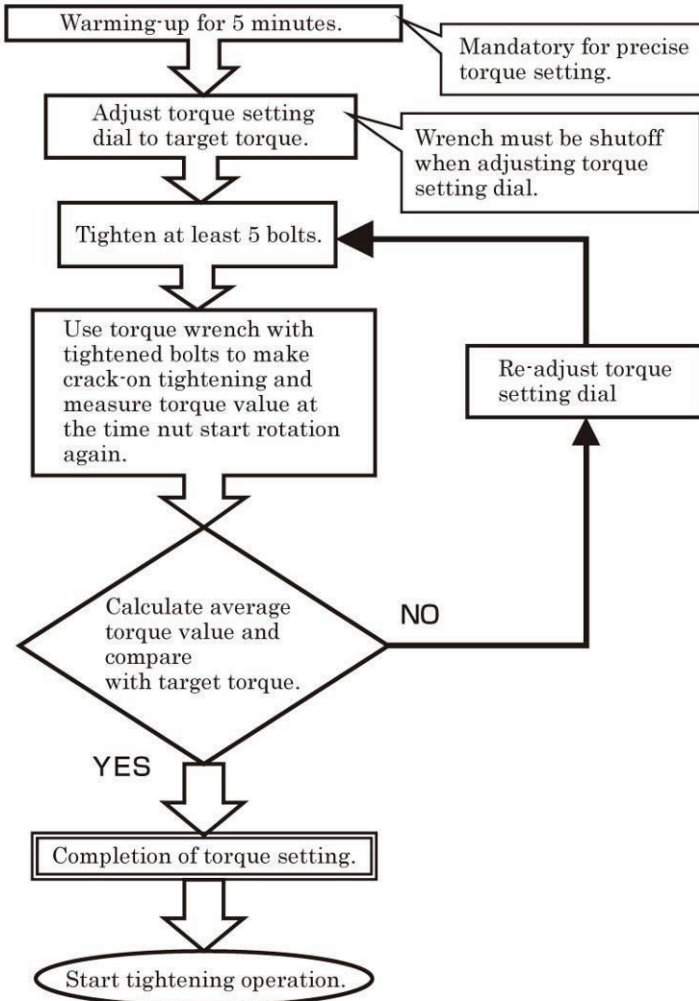

 **CAUTION**

- **Gradually adjust torque setting dial from low torque to high torque to prevent over loading.**

- Tightening torque varies depending on tightening condition such as condition of bolt/nut, surface condition of steel, length of extension cord, voltage use and etc.
- Tendency shown as below:

Tightening Condition	Tendency
<ul style="list-style-type: none">- When connection is soft (gasket, rubber, glass & etc in between the steels)- When bolt length is extremely long,- When bolt grades are under 8.8 or 10.9- When friction coefficient of the bolt is high- When bolt or washer is stripped during tightening- When voltage is higher than rated voltage of the wrench	Tightening torque becomes LOW
<ul style="list-style-type: none">- When connection is hard- When bolt diameter is large- When bolt length is short- When water or oil is adhered on the bolt- When tightened bolt is tightened again (over tightened)- When voltage is lower than rated voltage of the wrench	Tightening torque becomes HIGH
<ul style="list-style-type: none">- When gaps between the connection is large	Result in imprecise tightening

 **CAUTION**

- **Never re-tighten the same bolt/nut that has once successfully installed (never over tightened the same bolt/nut).**

Failure to follow this instruction may result in breakage of the bolt/nut, malfunction, personal injury or loss of torque precision.

8. Using Display

8-1. Turn Display ON

When microSD card is inserted

Approx. set up time: 9 sec

- ① Press **PWR** button for approx 1 sec at no-load.



- ② All digits will appeared in the window and power is turn on.



- ③ **5d.in**, will appear in the window if micro SD card is properly installed.



- ④ **R5.on** will appear if Auto Start is selected. No **R5.on** sign will appear if Auto Start is not selected.

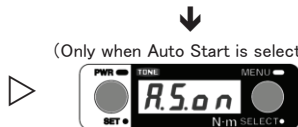

(Only when Auto Start is selected)

- ⑤ Year, date and time will appear in the window in the following sequence:

- ➔ Calendar Year (no period)
- ➔ Month & Date (separated by 1 period)
- ➔ Hour & Minutes (separated by 2 periods)



NOTE No clock function won't appear if microSD card is not installed.

NOTE Press **SET** or **SELECT** button during step 3 & 4 to short cut initialization.



- ⑥ Zero adjustment will be made when **0000** is displayed and then zero adjustment is completed when **0** is appeared.



NOTE Zero adjustment is automatically made when power is just turned ON.

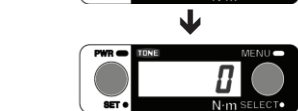

NOTE Set clock when calendar year is flashing. (see page 34)

When microSD card is not installed

Approx. set up time: 6 sec

- ① Press **PWR** button for approx 1 sec at no-load.



- ② All digits will appear in the window and power is turn on.



- ③ **no5d** (no microSD) will appear in the window if microSD card is not installed.



- ④ **R5.0n** will appear if Auto Start is selected. No **R5.0n** sign will appear if Auto Start is not selected.



- ⑤ Zero adjustment will be made when **0000** is displayed and then zero adjustment is completed when **0** is appeared.



NOTE Zero adjustment is automatically made when power is just turned ON.



NOTE When tightening torque is measured without microSD memory card, the clock is used only for purpose of “5-6 Display setting state and battery power level” (See Page 19.) In this case, setting the clock is not necessary.

⚠ CAUTION

- Never apply load during **0000** is displayed as zero adjustment is being made.
- Only apply load when **0** is displayed.
- **Er.Ol** (Error Over Load) will appear right after **8.8.8.8** is displayed when load is applied beyond rated torque range. Measured torque cannot be guaranteed in such case (see page 43).

8-2. Turn Display OFF

- Press **PWR** button for approx 3 sec to turn display off. **OFF** sign will appear.

NOTE Display shuts off automatically when it is not in use for more than 10 minutes (see page 40).

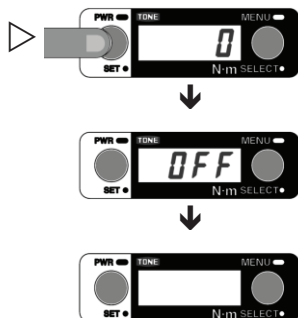

8-3. About Automatic Display Shut OFF

- ① **OFF** will flash when display is not in use for more than 10 minutes.

NOTE Press either **SET** or **SELECT** button during **OFF** is flashing to deactivate automatic shut off.

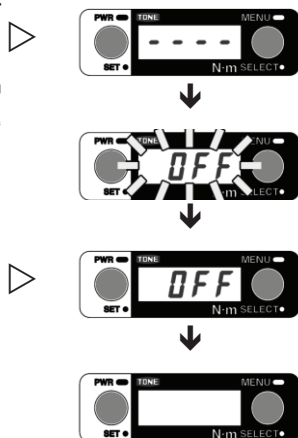

- ② After 10 seconds of **OFF** flashing, the display will be turned off automatically.

8-4 Battery Level

- Battery level are indicated as follows:

- **bA t _** (b A t tery falls)
- **bA t _** (b A t tery almost Low)
- **bA t L** (b A t tery completely Low)

Immediately change batteries when **bA t _**
bA t L are indicated. (see page 57)

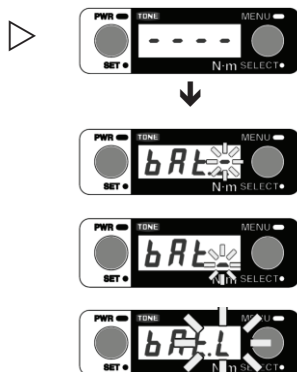

CAUTION

- No operation available other than shutting off the display when **bA t L** is indicated.

8-5. View result and automatic zero adjustment

- Press **SET** button to view torque value that is previously measured when **0** or **----** is shown in the window. Zero adjustment will automatically be made at the same time.

NOTE Display stores torque value previously measured even though it is turned off.

NOTE Zero adjustment must be made at no-load.

NOTE **0000** tells that zero adjustment is being made.

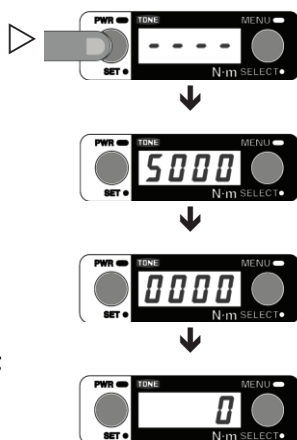

CAUTION

- Never press **SET** button when load is being applied.

8-6. View Setup Condition and Battery Level

- Setup condition and battery level can be review by pressing **SET ●** and **SELECT ○** buttons at the same time when **0** or **----** is indicating.

- **Sd.in** (microSD installed)
- no.Sd** (No microSD)
- **Auto On** (Auto Start **ON**)
- (No indication if Auto Start is **OFF**)

- Calendar Year (no period)
- Month & Date (separated by 1 period)
- Hour & Minutes (separated by 2 periods)

- **bAt.3** (**b** **A** **t** tery enough)
- bAt.2** (**b** **A** **t** tery falls)
- bAt.1** (**b** **A** **t** tery almost Low))

NOTE Keep pressing set & select buttons to proceed with clock setting (see page 52).

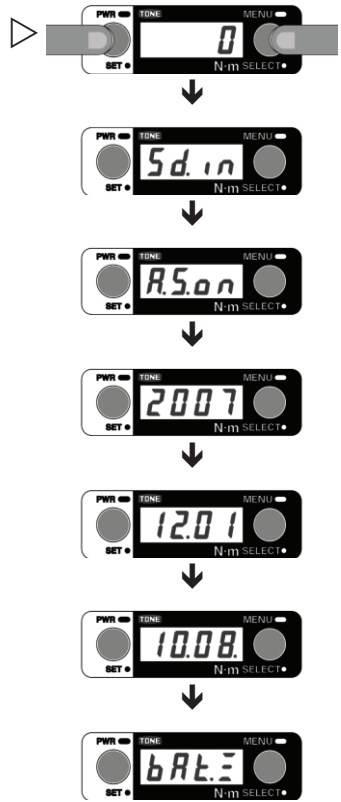

 CAUTION

- Make sure press **SET** button to show  each time before next tightening when auto start is **OFF**.

Torque will not be measured if tightening operation is started without displaying .

- Never apply load before  is displayed.

Failure to follow this instruction results in inaccurate torque measurement.

- Never press **SET** button when load is being applied.

Failure to follow this instruction results in inaccurate torque measurement.

- **Er.DL** (Error Over Load) will appear when load is applied beyond maximum torque of the wrench. Once **Er.DL** is displayed, it will continue to show up every time when power is turned on to give alert that measured torque cannot be guaranteed.



- Contact your distributor for repair and recalibration.

Failure to follow this instruction results in inaccurate torque measurement.

- Change batteries when **bAtL** is displayed. (see page 24)



8-7. MENU Function

Setup, edit or modify group file, file title, auto start function and clock by pressing **MENU** button.

Show Menu Screen

- ① Press **MENU** for approx 1 sec when **0** or **----** is displayed in the window to proceed with menu screen.

NOTE For list of menu screen, see page 45.



Select and Run Menu

- ② Press **SELECT** to proceed with next menu.



- ③ Press **SET** to run menu.



Finish Menu Screen

- ④ Press **MENU** for approx 1 sec to finish menu screen.



NOTE Zero adjustment will not be made although **0** is displayed when menu screen is finished, Press **SET** to make zero adjustment before tightening.

Menu Screens

 1_CHANGE GROUP

[1_CHANGE

▷ Change group file (see page 46)

 2_GROUP DATA

[2_GROUP DATA

▷ View measured torque values in a selected group file (see page 47)

 3_FILE TITLE

[3_FILE TITLE]

▷ View title of group file (see page 48)

4_AUTO START

[4_AUTO START

▷ Setup auto start ON/ OFF
(see page 49)

5_SET DATE

[5_SET DATE]

▷ Setup clock (see page 52)

 **NOTE** Menu mark with  tells that microSD card installation is necessary.

 **NOTE** Zero adjustment will not be made although 0 is displayed when menu screen is finished, Press SET ● to make zero adjustment before tightening.

8-7-1. Change Group File



(Only when microSD card is installed)

Torque data management can be done by group by saving the data in different group files.

① Call “Change Group” menu



② Press **SET** to run “Change Group” menu



③ Following **CLOSEd FILE:**, existing group file name is scrolled. In the next tightening measurement, the data will be saved in a new group file whose serial number is greater than the previous file name by 1.



NOTE When a group file is changed at the beginning on 2007/12/01 as described in “Data Folder Configuration (e.g.)” (See Page), the display scrolls the old group file name **CLOSEd FILE:07C01001**.

The group file named “07C01002.CSV” having a serial number incremented by 1 is the new data storage.

NOTE Example designation of group file name.

5 : Figure 「5」, **6** : Figure 「6」,
b : Alphabet 「B」, **d** : Alphabet 「D」

NOTE Group file name scrolls twice on the window. When **SET** or **SELECTO** button is pressed during scrolling, it immediately reads **0**.

NOTE Display **no CLOSE FILE** indicates that changeable group file is not found.

CAUTION The maximum number of tightening torque data that can be in a group file is 999 (up to TORQUE DATA No. 999).

If the number exceeds 999, the next data will be saved in the new file as created in step ③ above automatically. (See p. 49).

8-7-2. Display Tightening Torque Data in the Current Group File



(Only when microSD card is installed)

The tightening torque data in the current “Group file” can be checked sequentially by the button operation.

- ① On “Menu screen” (See Page 26), display and scroll the 2nd menu.



- ② Press **SET** to run the displayed menu.



- ③ Following  (indication of previous data), previous tightening torque is displayed.



NOTE If no operation has been done for approx 10 second, the display returns to  and measurement can be continued.



- ④ When displaying the tightening torque data older than the previous one, press **SET** button.



NOTE For fast data scrolling, press and hold the button.

NOTE If no operation has been done for approx 10 second, the display returns to  and measurement can be continued.

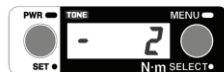

- ⑤ When displaying newer tightening torque data, press **SELECT** button.



NOTE For fast data scrolling, press and hold the button.

NOTE If no operation has been done for approx 10 second, the display returns to  and measurement can be continued.



8-7-3. Display Name of Group File



(Only when microSD card is installed)

The name of file in the microSD memory card to which the current group file is stored can be identified through the button operation.

- ① On “Menu screen” (See Page 26), display and scroll the 3rd menu.



- ② Press **SET** to run the displayed menu



- ③ Following **CLOSEd FILE-**, existing group file name is scrolled



NOTE When a group file is changed on 2007/12/01 as described in “Data folder configuration (e.g.)” (p. 49), the display scrolls the new group file name **GroUP FILE-07C01002**.



NOTE Example designation of group file name.

5 : Figure 「5」, **6** : Figure 「6」,
b : Alphabet 「B」, **d** : Alphabet 「D」

NOTE Group file name scrolls twice on the window. When **SET** or **SELECT** button is pressed during scrolling, it immediately reads **0**.

8-7-4. Turn ON/OFF Auto Start Mode

4_Auto Start

In the auto start mode, tightening torque measurement starts automatically as the variation in tightening torque is detected.

Advantage and Disadvantage of Auto Start Mode

	OFF	ON
Pressing Button	Press SET button before measurement	Not necessary
Zero Adjustment	Upon turning on the power, or at every measurement	Upon turning on the power, or only when pressing SET button.
Battery Life	Complying with Specifications	Depending on usage condition

- ① On “Menu screen” (Page.26), display and scroll the 4th menu.

4_Auto Start:OFF indicates that auto start mode is currently OFF.

4_Auto Start:ON indicates that auto start mode is currently ON.

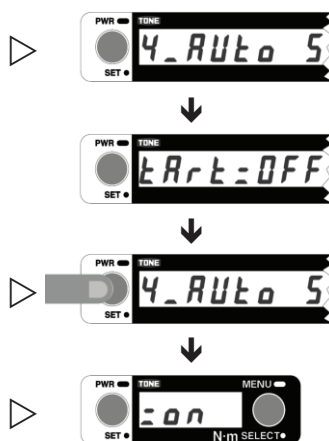

- ② Press **SET** to run the displayed menu.

- ③ The current mode is displayed.

CAUTION When the torque measurement is started with the auto start mode **ON**, tightening torque will be measured with reference to “Zero adjustment” performed immediately after power **ON**, or to “Zero adjustment” performed upon displaying the previously measured peak torque value by pressing **SET** button. If “Zero adjustment” has not been made for a long time, press **SET** button and manually perform “Zero adjustment”

CAUTION The **ON** / **OFF** setting data of auto start mode will be stored and retained after turning off the power.

CAUTION If **R5.0n** is not displayed upon the power on, the auto start mode is **OFF**. **SET** must be pressed to start measurement.

CAUTION When the tightening torque is measured with auto start mode **ON**, the battery life can be shorter than that with auto start mode **OFF** due to increasing power consumption.

CAUTION When the tightening torque is measured with auto start mode **ON**, always check remaining battery level (See Page 20).

○ Tightening procedure when auto start mode is **ON**

① Tighten bolt/nut with POWER DIGITORQON while the tightening torque or **0** is displayed.

NOTE “Zero adjustment” can be started by pressing **SET** button (See Page 36).

CAUTION Before starting “Zero point adjustment” by pressing **SET** button, check the reaction bar for no loading.

② As POWER DIGITORQON stops, the maximum tightening torque measured during tightening procedure is displayed. To continue the measurement, repeat procedure with step 1).

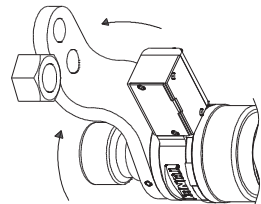

NOTE For tightening operation, refer to section 6. Operating procedure (pp. 25–29).

NOTE When microSD memory card is installed, the tightening torque value is saved to “Group file” in the memory card (See Page 22)

NOTE When no operation has been attempted for more than 10 min. “Automatic power off function” turns off power (See Page 20).

CAUTION When a tightening torque exceeding the maximum torque that can be displayed on POWER DIGITORQON is measured, the window reads **Er.DL** (Error Over Load) in place of the tightening torque, and accuracy of tightening torque reading cannot be guaranteed (p.38).

○Tightening procedure when auto start mode is **OFF**

- ① When is not displayed, press **SET** button to display .



NOTE The window reads for approx 0.5 second while “Zero adjustment” is automatically performed (See Page)

CAUTION Before starting “Zero point adjustment” by pressing **SET** button, check the reaction bar for no loading.

- ② Tighten the bolts/nuts with **POWER DIGITORQON**.

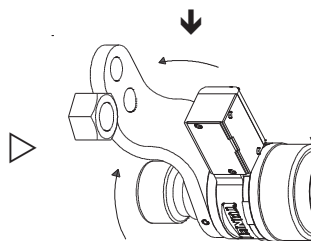

- ③ As **POWER DIGITORQON** stops, the maximum tightening torque measured during tightening procedure is displayed. To continue the measurement, repeat procedure with step 1).



NOTE For tightening operation, refer to section 6. Operating procedure (pp. 25–29).

NOTE When microSD memory card is installed, the tightening torque value is saved to “Group file” in the memory card (See Page 22)

NOTE When “Auto start mode” is **OFF**, power saving message will be displayed after a given length of time.

NOTE When no operation has been attempted for more than 10 min. “Automatic power off function” turns off power (See Page 20).

CAUTION When a tightening torque exceeding the maximum torque that can be displayed on **POWER DIGITORQON** is measured, the window reads **Er.O.L** (Error Over Load) in place of the tightening torque, and accuracy of tightening torque reading cannot be guaranteed (p.38).

8-7-5. Set Clock

5.SET dAtE

- ① On “Menu screen” (See Page 26), display and scroll the 5th menu.



- ② Press **SET** to run the displayed menu.



- ③ “Clock setting screen” appears and blinks calendar year.



- ④ Repeatedly press **SELECT** button until the current year is displayed.



- ⑤ Press **SET** button to acknowledge the year, and then a month blinks.



In the same way as for the year setting set the month, day, hour and minute in that order.



- ⑥ The window, after displaying the date and time, returns back to **0** display, indicating that tightening torque can be measured.

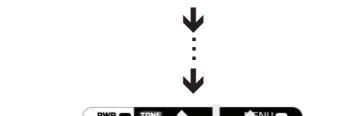

NOTE For fast figure scrolling, press and hold **SELECT** button.

NOTE When tightening torque is measured without microSD memory card, the clock is used only for purpose of “5-6 Display setting state and battery power level” (See Page 19.) In this case, setting the clock is not necessary.

9. microSD memory card storage format

“DIGITORQON” saves measurements of tightening torque to **Date Folder** and **Group File** on the microSD memory card in the data folder format as shown in the figure below.

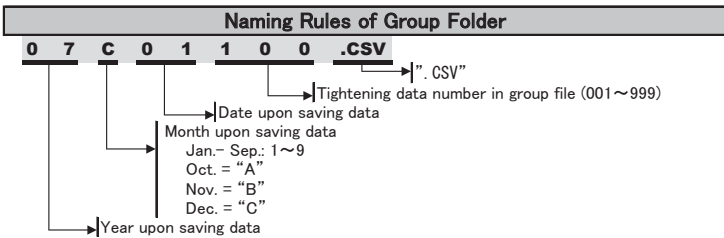
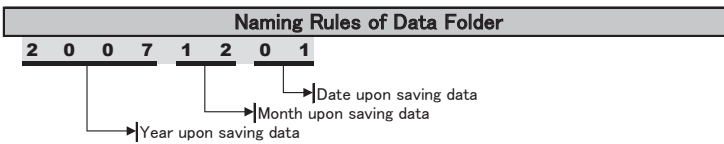
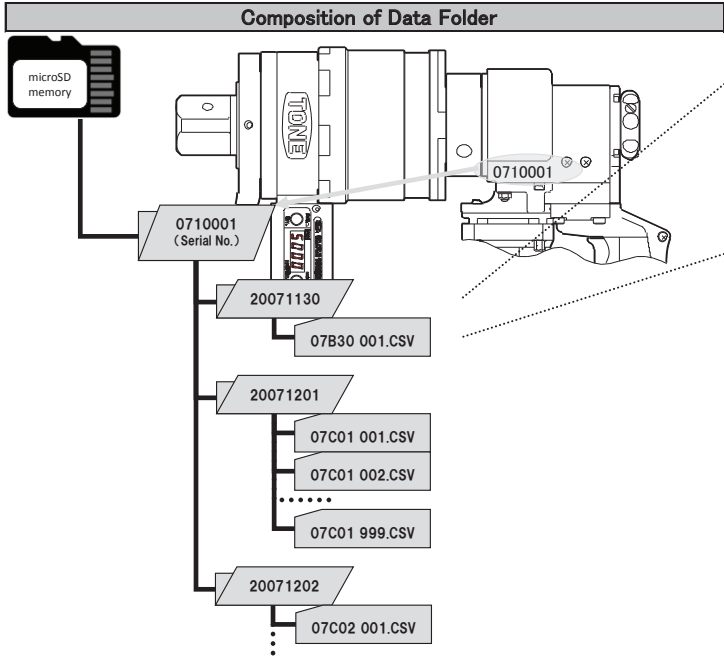

Storage Format of Group File

SERIAL No.,0710001

DATA No.,TORQUE[Nm],TIME[hh:mm:ss],DATE[YYYY/MM/DD],OVERLOAD,OPERATION,Remark_1

1,800,16:21:00,2007/12/01,PowerON,

2,801,16:22:31,2007/12/01,,ZeroAdjustment,

3,799,16:23:20,2007/12/01,,AutoStart,

4,800,16:24:15,2007/12/01,,AutoStart,

5,799,16:25:31,2007/12/01,,AutoStart,

.....

998,1001,23:58:59,2007/12/01,ErrorOve

999,800,23:59:59,2007/12/01,,ZeroAdjustment,

(ファイルの最後)

Open Group File with
spreadsheet . . .

DATA No.	TORQUE[Nm]	TIME[hh:mm:ss]
1	800	16:21:00
2	801	16:22:31
3	799	16:23:20
4	800	16:24:15
5	799	16:25:31
.....		
998	1001	23:58:59
999	800	23:59:59

- The serial number of “DIGITORQON” is placed at the top of the group file.
- In the group file, data is arranged in CSV (comma separated value) text format and in the order of DATA No., TORQUE (tightening torque), TIME (hour, minute, second), DATE (year, month, day). A data line is added as another tightening torque measurement is carried out.
- The maximum number of tightening torque data that can be in a group file is 999 (up to TORQUE DATA No. 999). The next data will be saved in a new group file having a serial number larger than that of the old file by 1.
- By pressing MENU button and then running I_CHANGE Group (Change group file), change the group file to which tightening torque data are saved. (See page)

NOTE Tightening torque data management can be done to read in the microSD memory card with available spreadsheets.

NOTE To read data folder and group file stored on microSD memory card on a PC, a memory card reader compatible with microSD memory card/SD memory card is required

NOTE microSD memory card can store the following data.

Storage Condition	Target
Size of 1 group file (tightening torque = 999)	Approx. 82KB
Number of pieces saved on microSD memory card (1GB)	Approx. 13 million

NOTE TransFlash Card compatible with the microSD memory card is also enable on “DIGITORQON”

CAUTION

- If microSD memory card is not in the microSD slot upon turning on the power to “POWER DIGITORQON”, tightening torque data will not be stored on the microSD memory card (See Page 11)
 - Check for display of **5d.in** upon turning on the power (See Page 14).
- When the microSD memory card is in the microSD slot, tightening torque data will be stored regardless of setting of auto start mode **ON/OFF**
- The data folder contains, **LAST#GRP.TXT** and **LAST#TRQ.TXT**
Since these files are special ones and therefore their file names shall not be changed.
- Do not touch electrodes of microSD card, and terminals and parts on the electronic substrate: static electrical charge will cause faults.
- A microSD memory card that can be used on “POWER DIGITORQON” has memory size of up to 2 GB.
- For information on handling method and warranty of the microSD memory card, refer to the card instruction.
- Maeda Metal Industries is not liable for any loss to any data stored to the microSD memory card with “POWER DIGITORQON”, regardless of reason or cause.
- Under no circumstances (except when disclaimer of liability is prohibited by law) shall Maeda Metal Industries be liable to the user for any special, indirect, incidental, or consequential damages including those to other devices, loss of data, etc., caused by abuse or misuse of “POWER DIGITORQON” or microSD memory card by the user or third party.

10. Changing Batteries

- ① Make sure that power is OFF (⇨ P.)



- ② Rotate the display control section until the torque display window faces down.

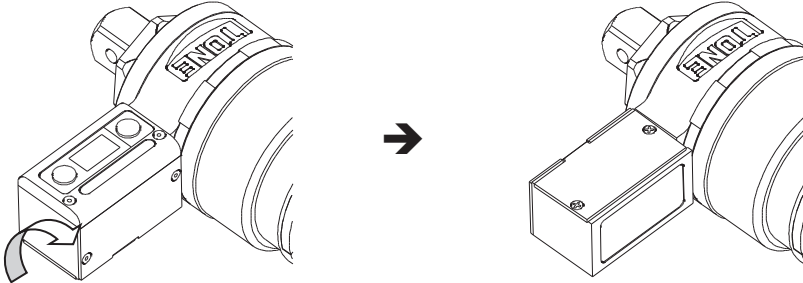

- ③ Using the stubby screwdriver, unscrew 2 screws (+ head) from the back side of the torque display window and then remove the cover.

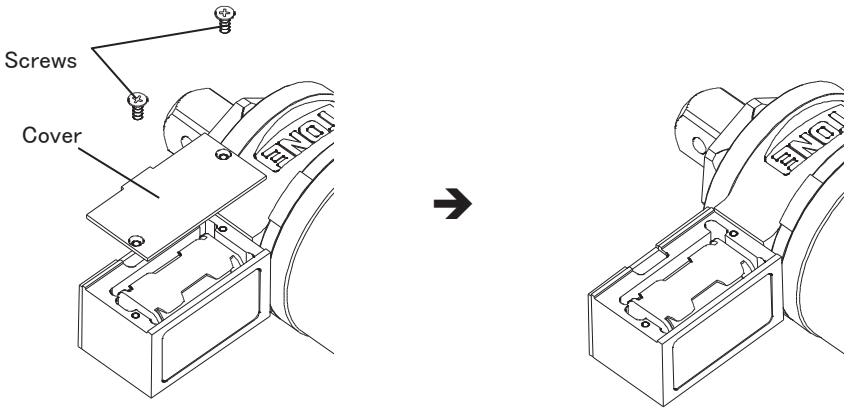

CAUTION Do not allow dust to enter the case.

CAUTION Do not remove other covers secured with hexagon socket head bolt. These covers prevent faults caused by static charge.

- ④ Remove the battery case from the display control section and remove the batteries.

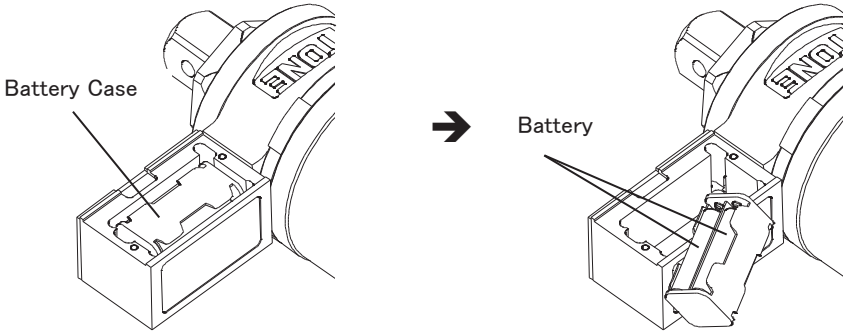

⚠ CAUTION Pay attention to the wiring while taking out the battery case.

⑤ Install new 4 batteries.

⚠ CAUTION Use size AA alkaline dry cells or nickel hydride rechargeable batteries.

⑥ Replace the battery case into the display control section. Make sure that the wiring is not bitten. Return to step 3 and perform procedure in the reverse order.

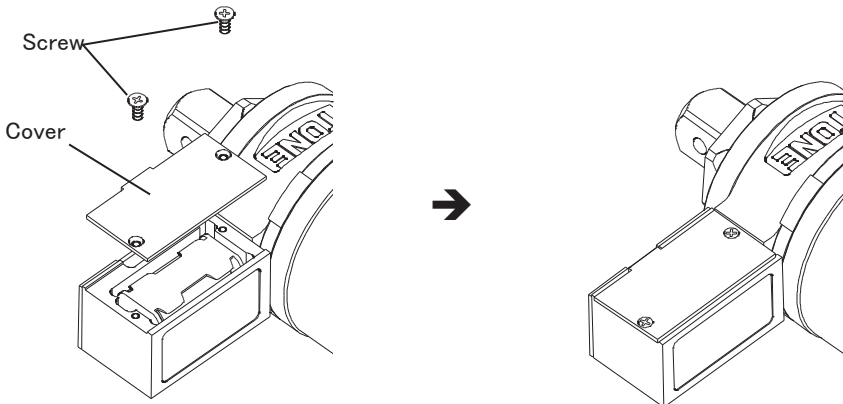

⑦ The clock display blinks. Adjust the clock as necessary by referring to description on (↩)page 47.

WARNING

- **Use size AA alkaline dry cells or nickel hydride rechargeable batteries.**

Failure to heed this warning will cause fire, burn wound, injury, accident, malfunction, liquid leakage or accuracy issue.

- **Handle batteries with care.**

- Install the batteries with correct polarity by referring to the markings on the battery case.
- Do not put batteries into fire. Do not short circuit batteries. Do not subject batteries to heat, deformation or decomposition.
- Do not use new battery with old battery. Do not use dry cell with rechargeable battery.
- Do not attempt to recharge a dry cell.
- If battery electrolyte enters eye, immediately rinse the eye with clean water and receive medical treatment.
- If battery electrolyte adheres to skin or clothes, wash it off with clean water.
- Discard of exhausted battery. Remove the batteries when the wrench is to be left unused.
- **Follow precautions on the battery.**

Failure to heed these warnings will cause fire, burn wound, injury, accident, malfunction, liquid leakage or accuracy issue.

CAUTION







- **Do not touch electrodes, terminals and parts on the electronic substrate: static electrical charge will cause faults.**

- **Do not allow dust to enter the case.**





11. Error and Status indication

11-1. LED for judgment and error indication







DIGITORQON is provided with green and red LED that indicate whether the tightening has successfully completed or not, or an error has occurred or not.

 : Lights Out
   : Light On
  : Quick On & Off (5 times/sec)
 : On & Off (2 times/sec)
  : Slow On & Off (1 times/sec)

Normal Condition

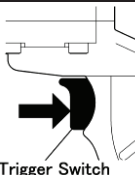
Indication	LED Meaning	Indication	LED Meaning
 ↓ After 1 sec. 	Power ON ↓ "Ready"	 ↓ Start Tightening  ↓ Complete Tightening 	No-load operation ↓ Tightening operation ↓ Tightening Finished

Trouble Detected

Indication	LED Meaning	Remedy
	<ul style="list-style-type: none"> • Tightening was not finished normally. • Release trigger switch before tightening finished. • Tightening the same bolts twice. • Inching action detected. 	<ul style="list-style-type: none"> • Check tightened bolts and nuts. • Do not release trigger switch during tightening. • Never tighten the same bolts twice. • Avoid inching action of trigger switch.
 ↓ Reset  Ready	 <p>Trigger Switch</p>	<Method of Reset> * To reset the wrench, squeeze the trigger switch once. And then, the wrench is now ready.
 <hr/>  <hr/>  ↓ Alternation 	Troubles happen on the "DIGITORQON"	Need to repair. Contact your distributor.

11-2. Error and Status Indication of Torque Readout Device

- ▷ **[Error Over Load]**
Load is applied beyond maximum torque of “DIGITORQON(⇨P.42)
- ▷ **[Error Revers Rotation]**
Counter clockwise rotation is detected.
- ▷ **[Error microSD]**
Incompletely installation or lack of storage can happen for the microSD memory card.
- ▷ **[no microSD]**
microSD not installed (⇨P.24)
- ▷ **[microSD in]**
microSD installed(⇨P.24)
- ▷ **[Auto Start = on]**
Auto start mode ON.(⇨P)
- ▷ “Zero Adjustment” is made(⇨P.40)
- ▷ **[no data]**
No tightening torque data in the current group file.(⇨P)
- ▷ **[Battery Level = 3/3]**
Battery Full(⇨P.40)
- ▷ **[Battery Level = 2/3]**
Battery falls(⇨P.40)
- ▷ **[Battery Level = 1/3]**
Battery almost low(⇨P.40)
Change batteries(⇨P.56)
- ▷ **[Battery Low]**
Battery completely low
Change batteries(⇨P.56)

12. Inspection & Maintenance

WARNING

- **Disconnect plug from power source before inspection and maintenance.**

Accidental starting invites serious injury.

- ① Use only a damp cloth to clean your POWER DIGITORQON and impact sockets since certain cleaning agents and solvents are harmful to those parts. Some of these include: benzene, thinner, gasoline and etc.
- ② Never put solvents into the exhaust vent.
- ③ Store POWER DIGITORQON in the metal case after operation and keep it dry.
- ④ Carbon-brush must be regularly inspected and replaced with the new genuine carbon brush when brush length become less than 6mm as following figure.

*Carbon brushes are placed in two positions.

*Indicate the wrench model when carbon-brushes are needed because carbon-brush differs from model to model.

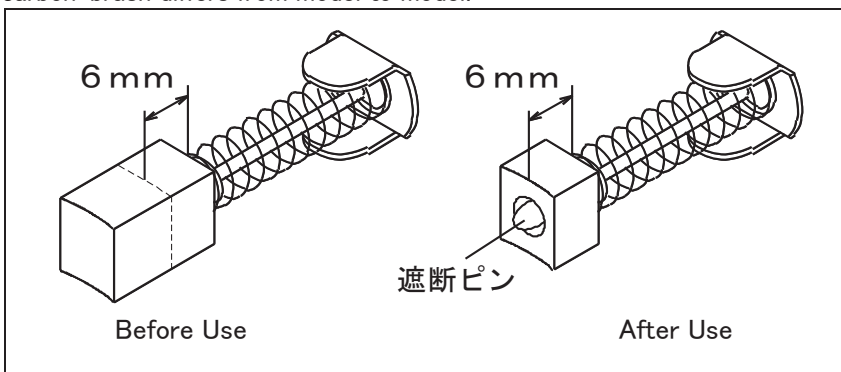

- ⑤ Replace carbon brush as shown in the following figure.

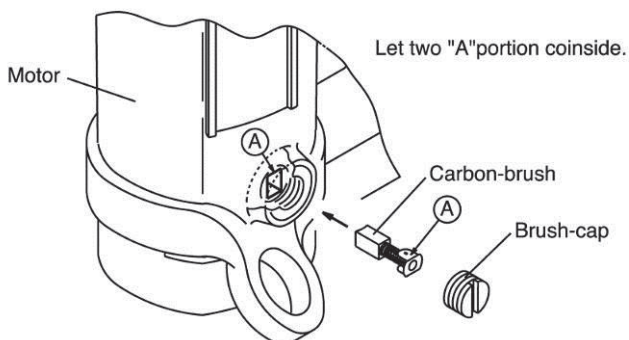

13. Regular Inspection

- Carry out overhaul once a year or 5,000 tightening, whichever comes first. Contact your distributor for details of overhaul.
- The minimum storage period for spare parts of the products mentioned on this instruction manual is 7 years after discontinuing these products.

14. Features

- Double insulated electric wrench.
- Measures and indicates tightening torque.
- Tightening torque data management can be done to insert the microSD memory card into digital torque indicator.
- Reading tightening torque data and measurement time stored in CSV text format on microSD memory card on a PC.
- Tightening torque measurement starts automatically by installed Auto Start Mode.
- Automatically shut off when digital torque indicator is not in use for more than 10 minutes.
- Notify the time of changing batteries.
- When a tightening torque that exceeds the maximum torque to be displayed on the indicator is measured, the display alerts that accuracy of tightening torque reading cannot be guaranteed
- Digital torque indicator turns 180 degree as below figure.

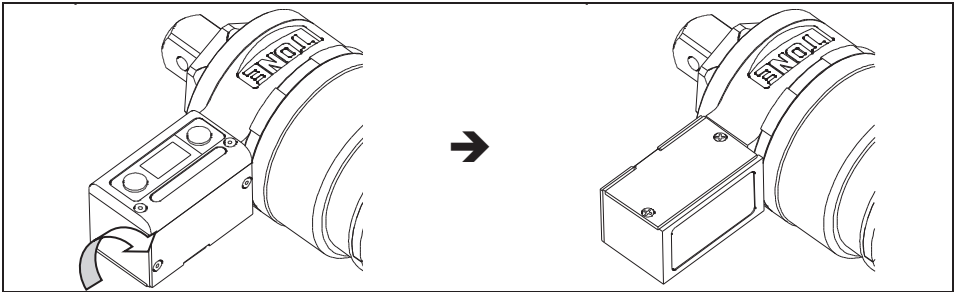

15. Specifications

Model		PDX -301N	PDX -302N	PDX -501N	PDX -502N	PDX -301F	PDX -501F
Voltage (Single Phase)		115V	230V	115V	230V	115V	115V
Max Current (A)		12A	6A	12A	6A	12A	12A
Max Power(W)		1350W 2s/3s				1350W	
Controllable Torque Range (N·m)		1,000 ~3,000Nm		2,000 ~5,000N.m		750~ 2,200 lbf·ft	1,500~ 3,700 lbf·ft
Repeated Accuracy (%) ※		+/-5%					
No-load Speed min ⁻¹ (rpm)		2min ⁻¹ (rpm)					
Measurement Direction		Clockwise Direction only					
Adoptable Bolt		Hexagonal Bolts					
Weight	Main Body (kg)		10.5kg	13.5kg	10.5kg	13.5kg	
	Reaction Plate (kg)	Straight	1.6kg	1.9kg	1.6kg	1.9kg	
		L-type	2.0kg	2.4kg	2.0kg	2.4kg	
Accuracy	Tightening Torque (%)		+/- 4% (Full Scale) (only with the attached reaction arm)				
	Clock		+/- 3 seconds per month (25°C) +/- 2 minutes per month (Max.)				
Battery		AA Alkaline X 4 or Nickel Metal Hydride Rechargeable Battery					
Battery Life		Approx 20,000 readings (Approx 170 Hours) (in case Auto Start Mode is <input type="checkbox"/> OFF with AAA Alkaline)					
Memory Card		microSD Memory Card (Max Storage: 2GB)					
Operating Temperature		0~40°C, humidity below 80% (no condensation allowed)					

※ Repeated Accuracy is to represent percentage of fluctuation of tightening torque under the same condition

- Commutator motor is used.
- Weight excludes socket and cord.

16. Aftersales Service

- Use “POWER DIGITORQON” properly according to this instruction manual and WARNING LABEL on the body of “POWER DIGITORQON”.
- Provide model, serial number, date of purchase and details of failure when contacting your distributor.

CAUTION

- Do not use “POWER DIGITORQON” when malfunction, deficiency in its performance, personal injury or property loss is foreseen.

If possible, prepare backup “POWER DIGITORQON” beforehand.

EC DECLARATION OF CONFORMITY

We hereby declare that the following our product conform to the essential health and safety requirements of EC Directives.

Directives : Machinery Directive, 2006/42/EC
EMC Directive, 2004/108/EC
RoHS Directive, 2011/65/EU

The above product has been evaluated for conformity with above directives using the following European standards. The technical documentation for this product is retained at the above manufacturer's location.

Machinery Directive:

EN 60745-1:2009+ A11:2010, EN 60745-2-2:2010

EMC Directive:

EMI EN 55014-1:2006 + A2:2011
EN 61000-3-2:2006 + A2:2009
EN 61000-3-3:2008
EMS EN 55014-2:1997 + A2:2008

Name : Motohiro Hirao
Title : General Manager Development Dept.
Address : 6-25, Kotobukicho, Kawachinagano-shi, Osaka,
586-0026, Japan
Signature : *MOTOHIRO HIRAO*
Date : 11 - May - 2013

TONE[®] TONE CO., LTD.



1-57, MINATOMACHI 2-CHOME, NANIWA-KU,
OSAKA 556-0017, JAPAN,

Web Site: <http://www.tonetool.co.jp>

e-mail: overseas@tonetool.co.jp

● Specifications and the design are subject to change without notice. ●